

INSTALLATION INSTRUCTIONS

WIDE SPAN SHELVEING

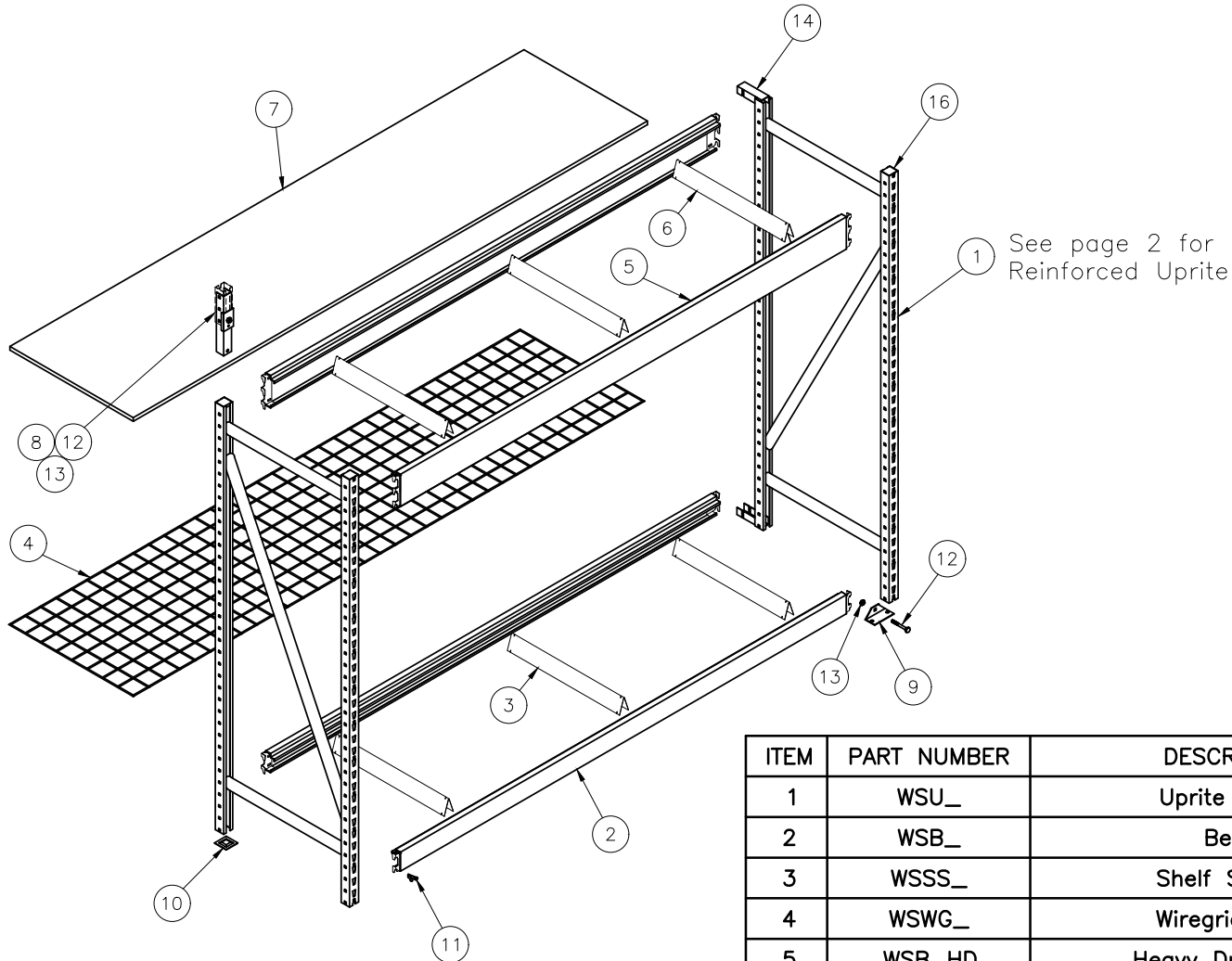

See page 2 for Reinforced Uprite

ITEM	PART NUMBER	DESCRIPTION
1	WSU_	Uprite Frame
2	WSB_	Beam
3	WSSS_	Shelf Support
4	WSWG_	Wiregrid Shelf
5	WSB_HD	Heavy Duty Beam
6	WSSS_HD	Heavy Duty Shelf Support
7	WSPB_HD	Heavy Duty Shelf
8	WSUC	Uprite Connector
9	WS1241	Floor Anchor
10	WS1251	Floor Protector/Shim
11	WS1291	Beam Locking Clip
12	50106	5/16"–18 x 2 1/2" Carriage Bolt
13	51005	5/16"–18 Hex Nut
14	WS1231	Back to Back Connector
15	WSU RE	Reinforced Uprite Frame
16	WS1321	Top Cap
17	WS9111	Beam Locking Hardware

NOTE: WIDE SPAN BEAMS ARE IDENTIFIED BY A **WS** STAMPED INTO THE RIGHT END OF EACH BEAM.

PLEASE NOTE: Personnel must be provided with safe access to all elevations of storage equipment or display fixtures via ladders, stairways, or other means in accordance with applicable OSHA regulations. In NO case should anyone be allowed to climb or stand on storage or display equipment.

INSTALLATION INSTRUCTIONS

WIDE SPAN SHELVING

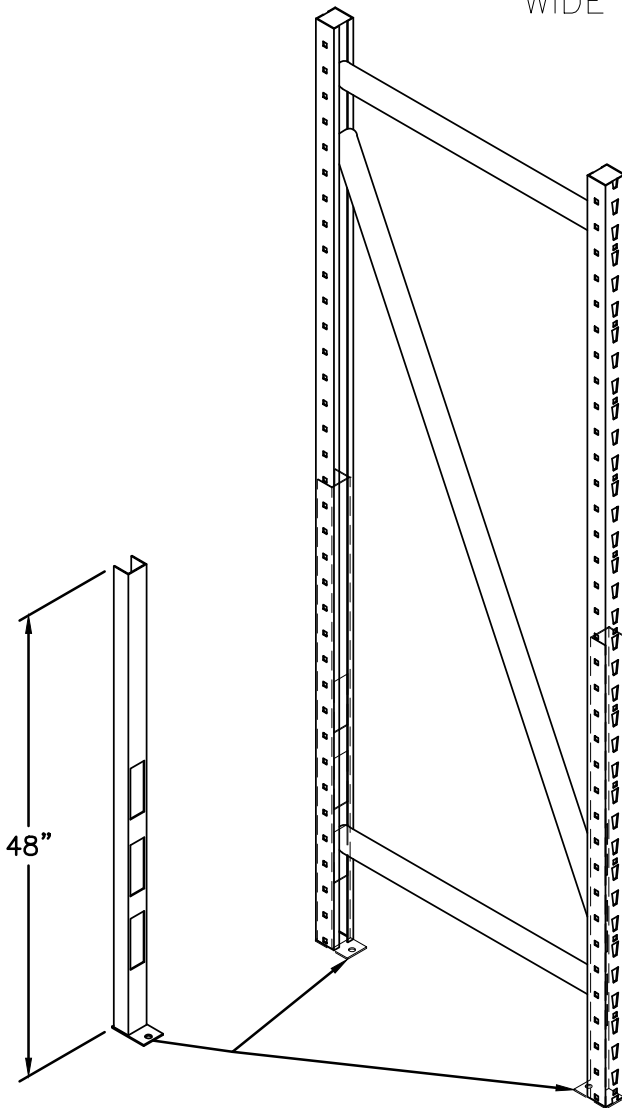

Reinforced Upright Frame (Item 15)

NOTE 1: Wide Span Upright Frames are available in standard duty for normal use or reinforced for use with hand stackers. (See User Instructions on page 10 for capacities.)

Reinforced Upright Frames (Item 15) have a channel shaped reinforcement member in the lower portion of each post. They also have a welded foot plate to secure the post to the floor.

Standard Duty Upright Frames (Item 1) DO NOT have the reinforcement member.

NOTE 2: Either of two beam types may be used with the Wide Span System (See User Instructions on page 9 and page 10 for capacities).

The Standard Duty Beam (Item 2) is 3 1/4" high.

The Heavy Duty Beam (Item 5) is 4 3/4" high.

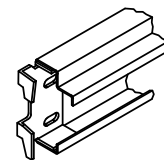

Standard Duty Beam (Item 2)

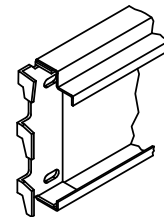

Heavy Duty Beam (Item 5)

INSTALLATION INSTRUCTIONS

WIDE SPAN SHELVING

SELF-RETAINING WIDE SPAN BEAM INSTALLATION

These Wide Span Beams are designed with Self-Retaining Lower Hooks on the End Connectors. The beam must be tilted so the longer lower hook can be inserted into the post slot first.

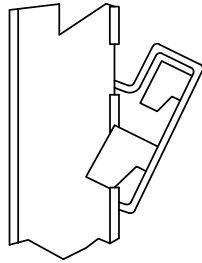

CORRECT

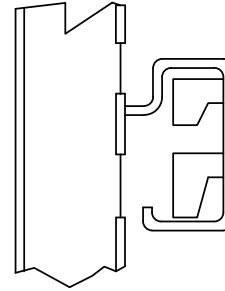

INCORRECT

STEP 1: Tilt top of beam and insert lower hooks into slots.

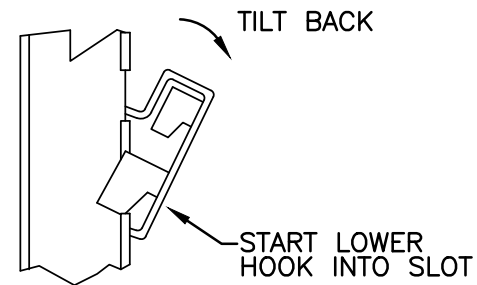

STEP 2: Rotate top of beam forward so top hooks are inserted into slots.

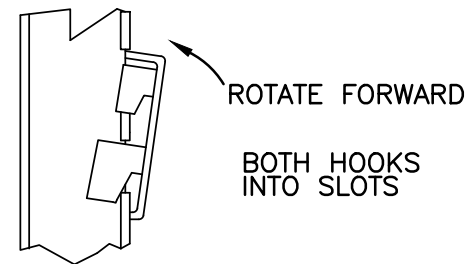

STEP 3: Seat the hooks downward into the slots.

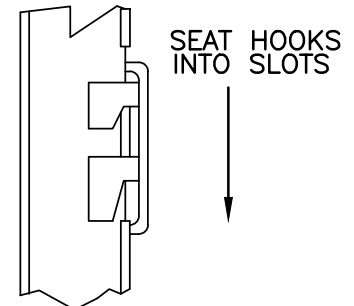

INSTALLATION INSTRUCTIONS

WIDE SPAN SHELVING

NOTE 3: Two styles of Shelf Supports may be used depending upon beam type:

Standard Duty Shelf Supports (Item 3) are 2-17/32" high and "∧" shaped.

These are used with Standard Duty Beams.

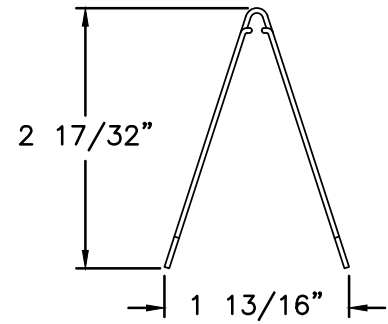

Standard Duty Shelf Support (Item 3)

Heavy Duty Shelf Supports (Item 6) are 4" high and "∧" shaped.

These are used with Heavy Duty Beams.

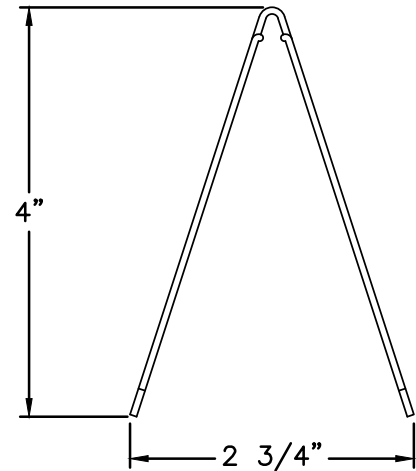

Heavy Duty Shelf Support (Item 6)

NOTE 4: Two Shelf types may be used:

3x3 Wire Grid (Item 4).

Heavy Duty Shelves (Item 7) are 5/8" thick, high-strength particle board.

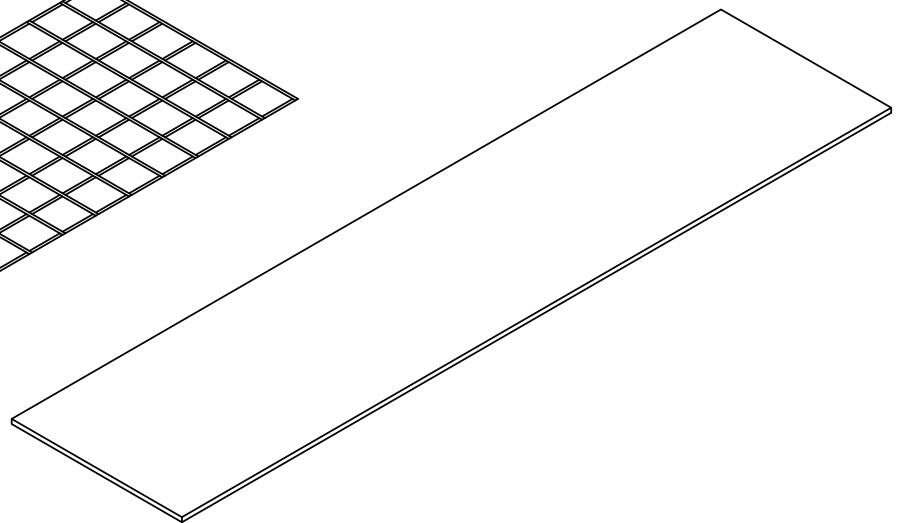
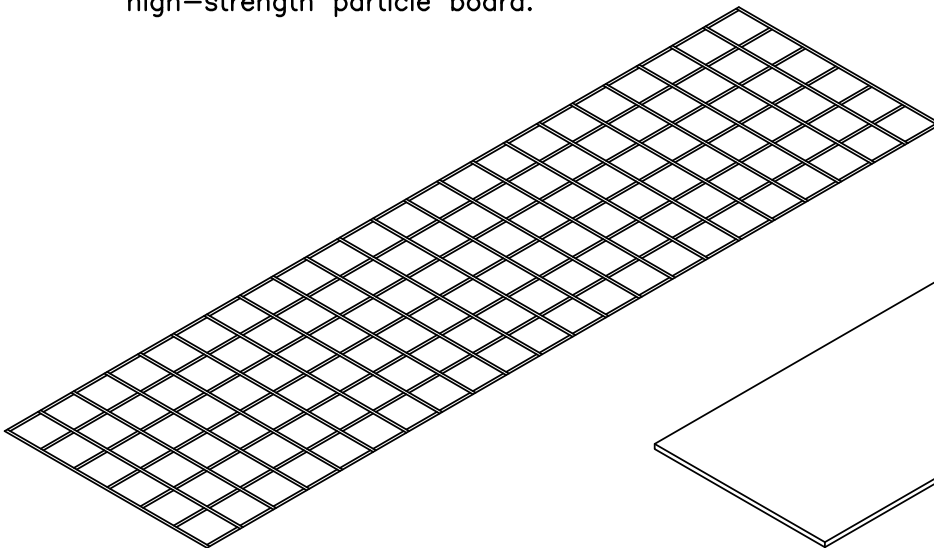

INSTALLATION INSTRUCTIONS

WIDE SPAN SHELVING

1. ASSEMBLY OF BASIC UNIT

NOTE: To provide for beams height adjustments, allow a 2" gap between wall and face of uprite (See Detail B) or between faces of both uprites in back-to-back applications or use back-to-back connectors (Item 14) (See Detail C).

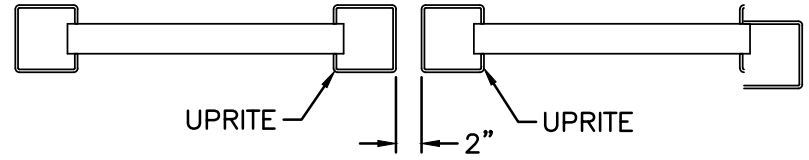
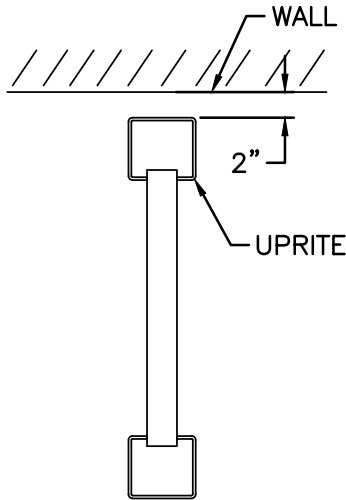

Top View of Upright Frames

- Stand two frames vertically (NARROW ENDS OF SLOTS DOWNWARD). Diagonal bracing on alternate uprite assemblies should face opposite directions per illustration on page 1.

WARNING: BE SURE REINFORCED UPRITES (Item 15) ARE INSTALLED IN AREAS WHERE HAND STACKERS ARE TO BE USED.

- Install one beam at lowest desired level. IF THE BOTTOM OF THIS BEAM IS MORE THAN 6" FROM THE FLOOR, THEN THE UPRITE MUST BE ANCHORED. Both ends of beam must be inserted into the uprite slots at the same time. (See Detail D)
- Install opposite side beam, following same procedure as outlined above.
- Install remaining beams at desired levels. Maximum beam spacing is 48" to maintain the uprite rated load capacities.

CAUTION: IF CERTAIN LEVELS ARE TO BE HEAVY DUTY, BE SURE HEAVY DUTY BEAMS ARE INSTALLED AT THOSE LEVELS. REFER TO LOADING INFORMATION IN USER INSTRUCTIONS ON PAGES 9 AND 10.

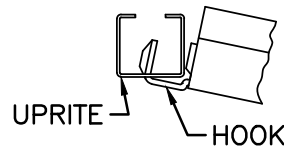
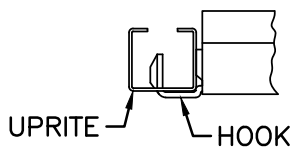

CORRECT **INCORRECT**
 (Top View of Upright Post and Left End of Beams)

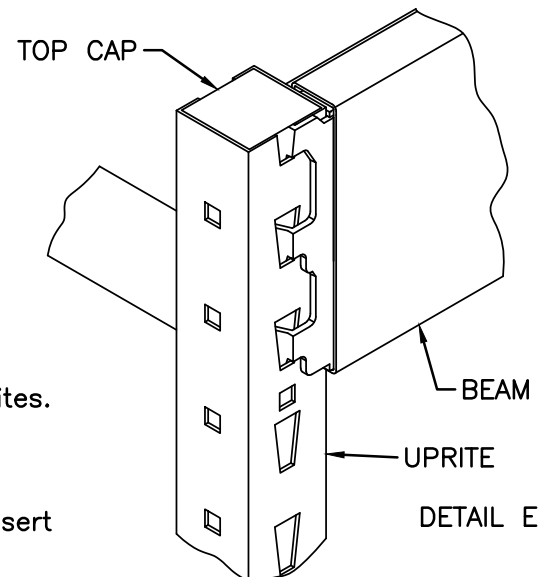

DETAIL E

NOTE: Be sure that:

- Hooks on all beams are properly seated and are square with uprites. (See Detail E)
- All beams are installed parallel with the floor.
- Front and rear beams of each pair are installed at same height.
- If top Lance in Uprite is going to be used remove Top Cap to insert Beam Hook and reinsert Top Cap (See Detail E).

INSTALLATION INSTRUCTIONS

WIDE SPAN SHELVING

e. When shelves are used, install Shelf Supports per Details F, G, and H. Shelf Support locations in the beams are as shown in Details F.

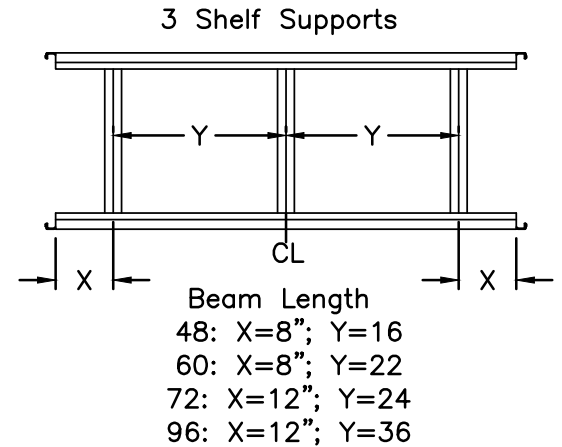
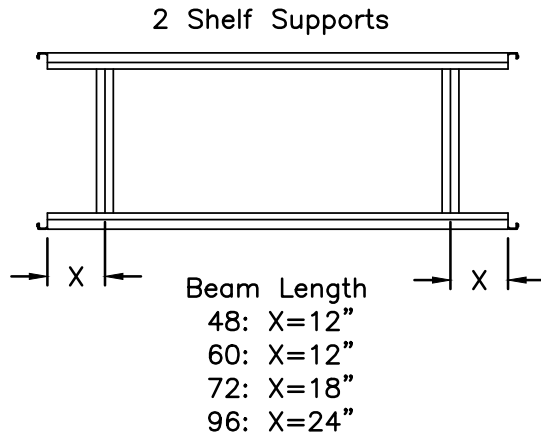

DETAIL F
(View From Top)

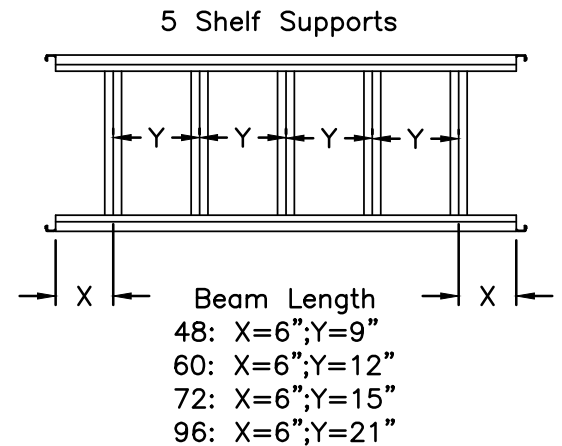
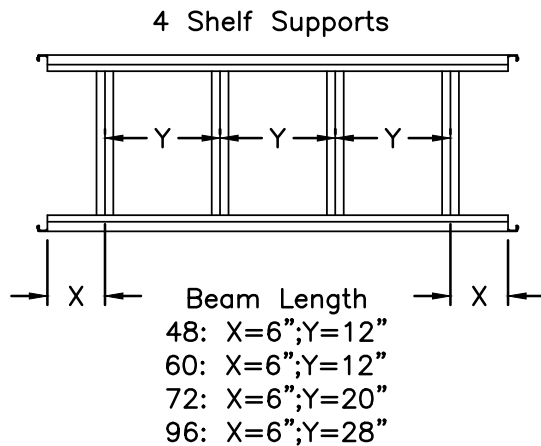

f. Shelf Supports (Item 3) are installed by laying them sideways between the beam flanges, then rotating them to vertical (See Detail G and H).

If outer supports fit to tightly, install them near center of the beams. Then slide them outward to the positions noted in Detail F above.

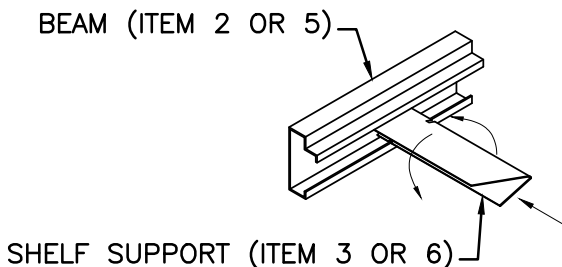

DETAIL G

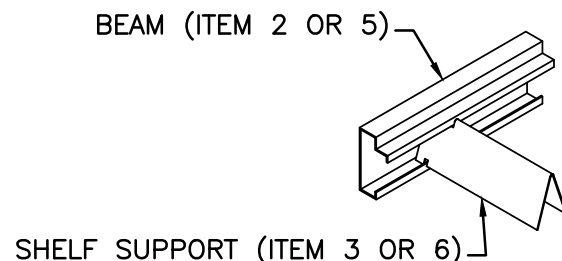

DETAIL H

INSTALLATION INSTRUCTIONS

WIDE SPAN SHELVING

2. FLOOR ANCHOR

Floor anchors are required when:

- The ratio of the height of the unit to the overall depth of the unit exceeds 6:1.
- Alignment of rows need to be maintained.
- When hand stackers are used.
- Post load needs to be spread over a larger area.
- When bottom of the bottom beam is more than 6" from the floor.

Bolt floor anchor onto the bottom of the post using hardware provided as shown in Detail I. Anchor to floor using a wedge-style anchor suitable for concrete. Anchor material, finish, diameter and embedment shall be determined by the customer for the specific site requirement.

The minimum anchor diameter shall be 1/4" and the minimum embedment shall be 1 1/8".

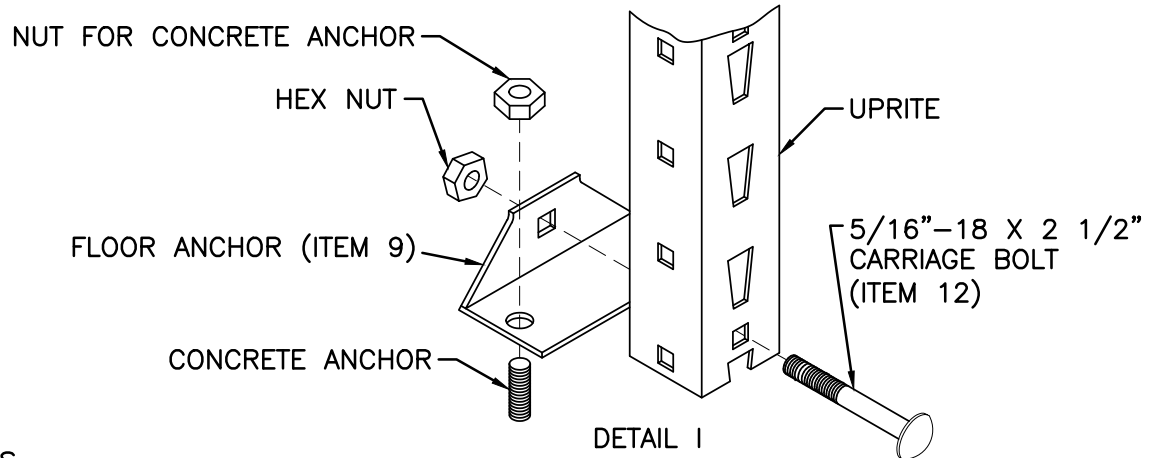

3. FLOOR PROTECTOR/SHIMS

Floor protector/shims are used to protect floors when required and/or to aid in leveling the system when required (by stacking the shims).

NOTE: FLOOR PROTECTOR/SHIMS CANNOT BE USED IN CONJUNCTION WITH FLOOR ANCHOR PADS.

- Install after assembly of basic unit by lifting one uprite at a time and then positioning shim (or shims) as shown in "Detail J". Do not exceed 5 shims under any post.

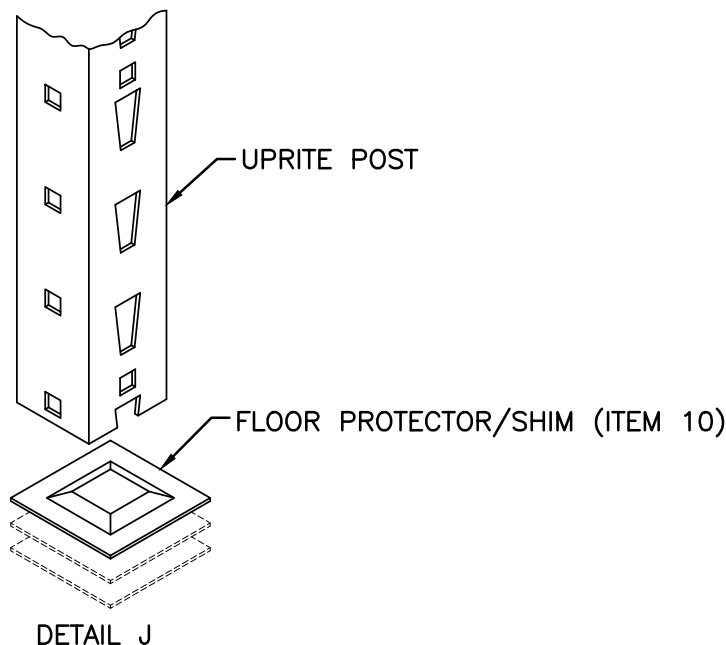

INSTALLATION INSTRUCTIONS

WIDE SPAN SHELVING

4. UPRITE CONNECTOR

Upright connectors are required for two-piece upright frames (those over 10' tall), and when adding height to existing installations. On two-piece upright frames and on extension frames, the lower upright frame should be equal to or greater in height than the upper upright frame.

- Remove Top Caps from lower upright frame.
- Slide a connector channel into the bottom of each leg of the upper upright frame. **MAKE SURE THE "C" CHANNEL SHAPE IS OPPOSITE THAT OF THE UPRIGHT POST.** Slip the carriage bolt through the square hole at the front of the upper upright post, then through the insert, then through the clamp. Install the nut loosely. When both connectors are installed, raise the upper upright frame into place per Detail L and tighten nuts snug. **DO NOT** over tighten as it will deform the face of the post.

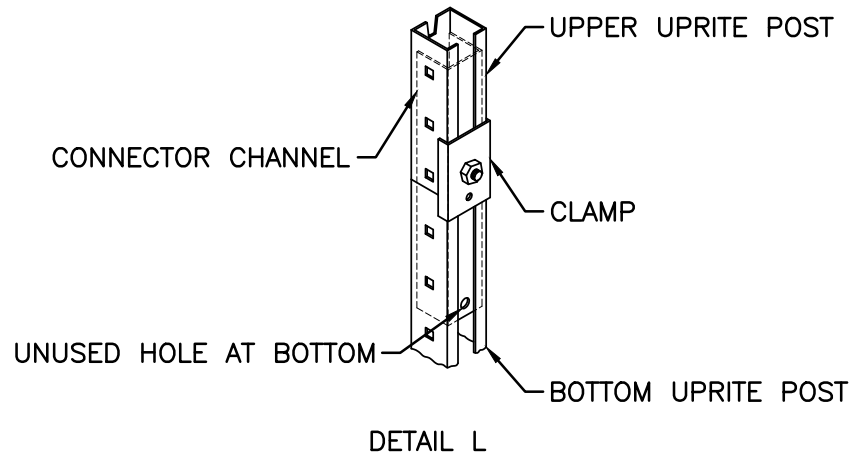
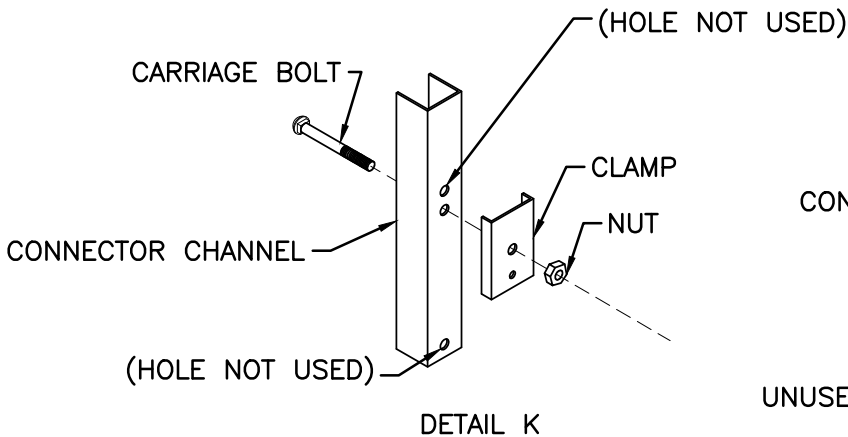

5. BACK-TO-BACK CONNECTORS

Back-to-back connectors are used to space back-to-back sections of Wide Span to allow beam adjustment.

- Set Upright Posts into slots in connector on floor (Detail M). (When floor anchors are used, lower back-to-back connector is not needed.)
- Place one connector over tops of back-to-back posts (Detail N), after removing Top Caps.

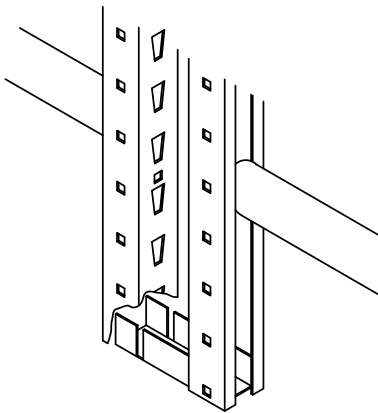

DETAIL M

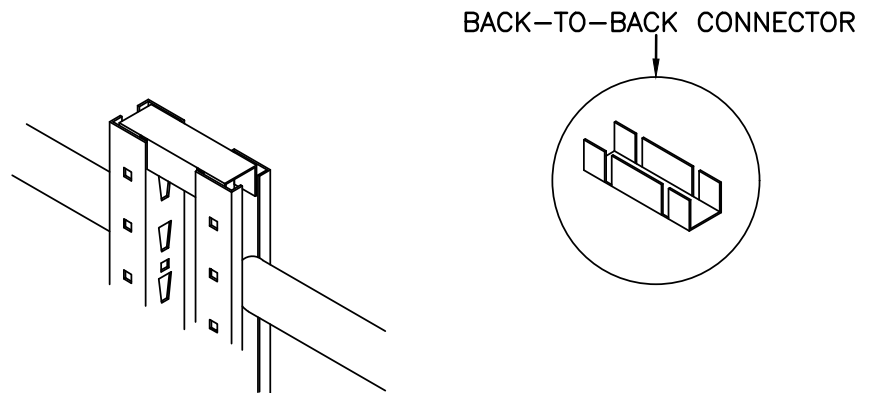

DETAIL N

INSTALLATION INSTRUCTIONS

WIDE SPAN SHELVING

STEP 6: BEAM LOCKING:

Beam locking clips (WS1291) or locking hardware (WS9111) must be used in the following applications:

- When beams are used singly, not as a beam pair with connecting shelf supports
- When hand stackers may be used to load and/or unload shelves
- When beam pairs will be used as tire racks

Locking clips must be oriented so that their tapered legs align with the tapered sides of the shelf slots in the upright post. The clips will not lock the beams unless they are correctly oriented when installed.

Insert the beam locking clip into the portion of the upright slot above the beam connector hook, as shown in Detail B. Always install the clip in the slots shown.



WARNING: DO NOT INSTALL THE LOCKING CLIP IN THE SLOT WITH BOTTOM HOOK OR THE TOP HALF SLOT OF THE UPRITE. THE CLIP WILL NOT LOCK THE BEAM IN THOSE SLOTS.

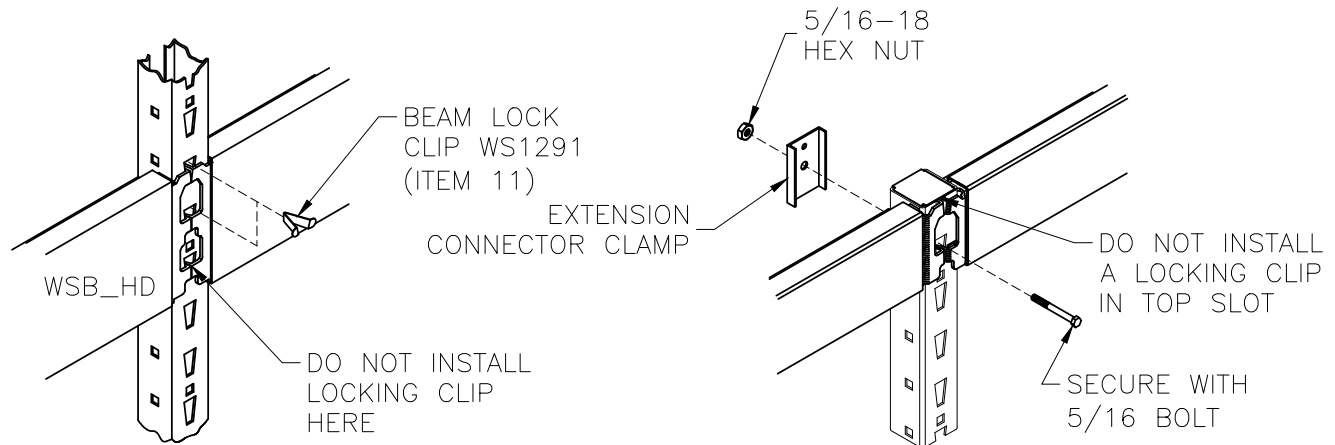
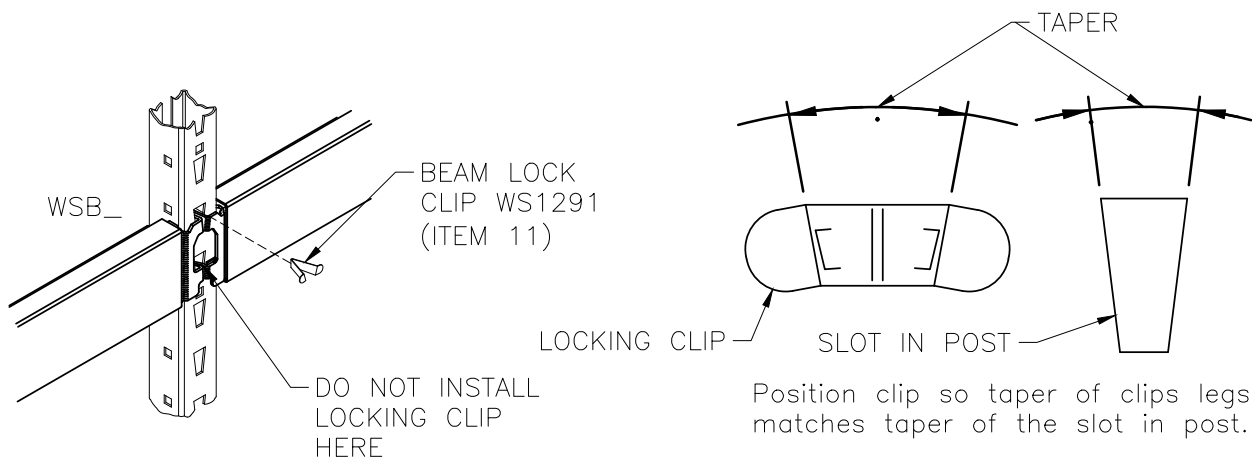

DETAIL P

WSB_ AT TOP OF WSU_:
BEAM LOCKING HARDWARE
WS9111 (ITEM 17)

STEP 7: TIRE RACK ASSEMBLIES:

The tire rack is assembled from standard components by following instructions on preceding pages. Use one shelf support near the center of each pair of beams to prevent the beams from spreading.

WARNING: BEAM LOCKING CLIP MUST BE USED ON ALL TIRE RACK BEAMS TO RESTRAIN BEAMS FROM BECOMING DISLODGED.

INSTALLATION INSTRUCTIONS

WIDE SPAN SHELVING

POST IN CONSPICUOUS PLACE

WARNING: OVERLOADING, MISUSE, ABUSE OF THE WIDE SPAN SYSTEM CAN CONTRIBUTE TO COLLAPSE AND PERSONAL INJURY!

PLEASE NOTE: Personnel must be provided with safe access to all elevations of storage equipment or display fixtures via ladders, stairways, or other means in accordance with applicable OSHA regulations. In NO case should anyone be allowed to climb or stand on storage or display equipment.

A. LOADING AND CAPACITY LIMITATIONS

1. Upright assembly – 10,000 pounds per upright assembly maximum:
 - Beams spaced not more than 48" vertically on center.
 - Post anchored to floor if bottom of bottom beam is more than 6" from floor
2. Standard Duty Beams (Hand Loaded Only)

WARNING: THESE CAPACITIES ARE FOR EVENLY DISTRIBUTED LOADS. CONCENTRATED LOADS REDUCE THESE CAPACITIES 50%.

- a. Maximum evenly distributed static load capacities per shelf with shelf supports (WSSS) and 5/8" thick particle board shelf (WSPB).

Widespan Shelf Capacity (Uniformly Distributed Load)						
Section Depth	Section Width (Beam Length)	Number of Regular Duty Shelf Supports with Regular Duty Beams			Number of Heavy Duty Shelf Supports with Heavy Duty Beams	
		2	3	4	2	3
Up to 36"D	48"	1,600	2,400	3,000	3,000	-----
	60"	1,600	2,400	2,400	-----	3,000
	72"	1,600	2,000	2,400	-----	3,000
	84"	1,600	1,800	2,000	-----	3,000
	96"	1,600	1,600	1,600	-----	3,000
Up to 42"D	48"	1,370	2,055	2,740	-----	3,000
	60"	1,370	2,055	2,400	-----	3,000
	72"	1,370	2,000	2,200	-----	3,000
	84"	1,370	1,800	1,600	-----	3,000
	96"	1,370	1,600	1,600	-----	3,000
Up to 48"D	48"	1,200	1,800	2,400	-----	3,000
	60"	1,200	1,800	2,400	-----	3,000
	72"	1,200	1,800	2,000	-----	3,000
	84"	1,200	1,700	1,800	-----	3,000
	96"	1,200	1,600	1,600	-----	3,000

- b. Capacities per pair of beams (with the required number of shelf supports (WSSS) to tie beams together) when load is placed across beams with no shelf.

Length	Capacity (Std. Duty)	No. of Shelf Supports Req. Per Pair of Beams
48"	3,000 lbs.	1
60"	2,500 lbs.	1
72"	2,000 lbs.	3
96"	1,600 lbs.	3

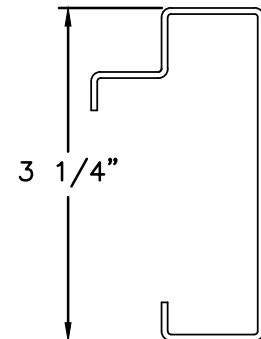

Standard Duty Beam

INSTALLATION INSTRUCTIONS

WIDE SPAN SHELVING

3. Heavy Duty – Three (3) heavy duty shelf supports are required per pair of beams.
a. Hand Loaded: 3,000 pounds per pair of beams (all lengths) – evenly distributed load.

WARNING: CONCENTRATED LOADS REDUCE THIS CAPACITY BY 50%.

- b. Hand Stacker Loaded:
2 – 1,000 pound pallets per pair of beams.
1 – 1,500 pound pallet per pair of beams.

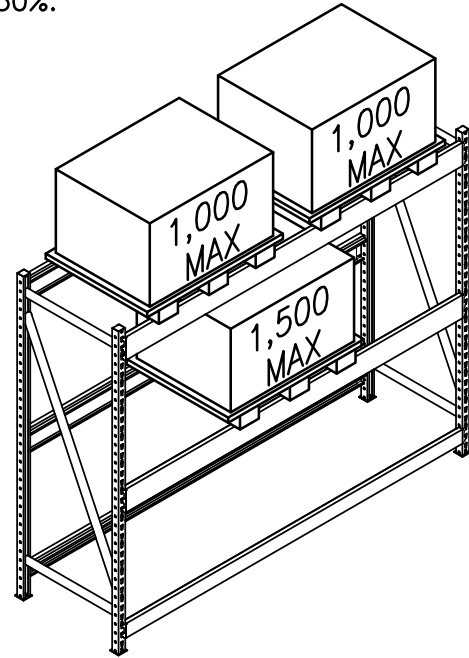
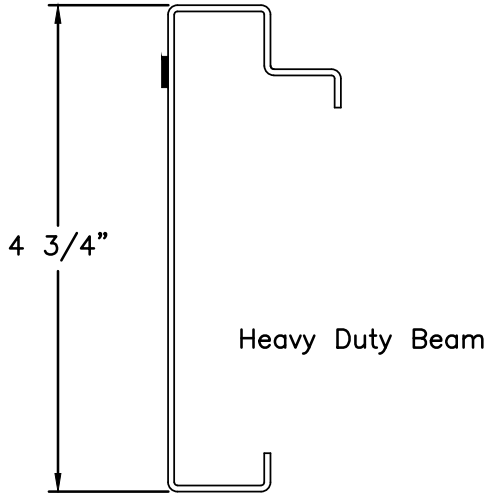

WARNING: HAND STACKERS (WALKER STACKERS) ONLY ARE ALLOWABLE. RIDER LIFT TRUCKS OF ANY TYPE ARE NOT ALLOWABLE.

- Beams must be heavy duty (WSB_HD)
- Beam locking clips are required on all aisle-side beams.
- Floor anchors are required on all aisle-side posts.
- Uprites (WSU_RE) with reinforcement members **MUST** be used.
- Pallets **MUST** sit on front and rear beams.
- Pallet sizes will be limited by the space between uprite posts. Approximately 3" clearance is required between pallets and between pallets and posts.



Hand Stacker

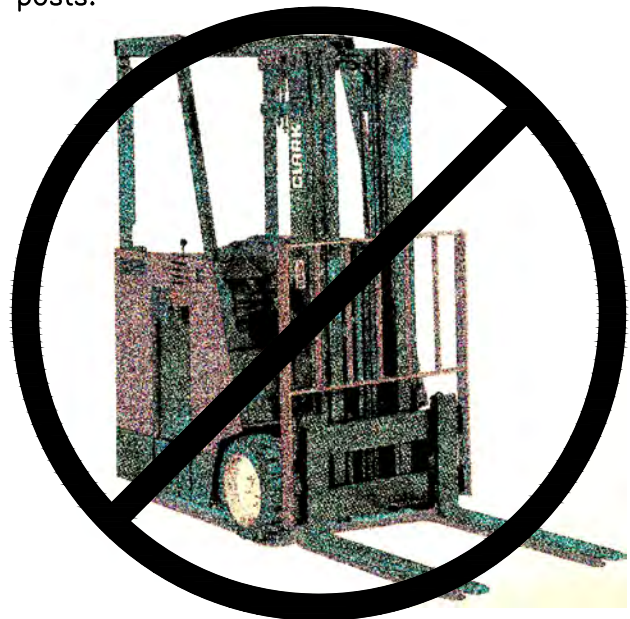

Forklift Truck

INSTALLATION INSTRUCTIONS

WIDE SPAN SHELVING

- B. SAFETY PRECAUTIONS – In order to assure that the Wide Span Shelving is used in a safe manner, the following safety precautions must be observed.
1. Racks MUST be installed strictly according to the manufacturers instructions.
 2. Local codes and regulations concerning building, fire, sanitation, or seismic requirements may apply to some installations. It is the responsibility of the owner of the fixtures to check with local building authorities to determine what codes or regulations, if any, apply, and always install the shelving in compliance with any such requirements.
 3. Never overload the uprights or beams (See Section A on pages 10 and 11).
 4. Be sure the shelving sections remain aligned.
 5. When the height of the rack is more than 6 times the depth, floor anchors must be used.
 6. Never use damaged parts. Damaged parts may cause shelving to be structurally unsafe or create exposure to sharp or pointed edges. If parts were damaged in shipment, do not use and contact your Lozier Customer Service Representative. If parts are damaged after shipment, discontinue use immediately and order replacement parts.
 7. Never alter, modify or otherwise structurally change the shelving or any of its component parts. Modification or alteration may cause the shelving or component part to become structurally unsafe resulting in tipping, collapse or other failure of the fixture.
 8. If any shelf support or beam becomes partially or completely dislodged, it must be corrected immediately.
 9. Do not use the installed Wide Span Rack as a ladder, walkway, or work platform.
 10. Do not lean tall or heavy items against shelving unless shelving is anchored to a suitable building wall, to the floor, or is otherwise braced to prevent overturning. The weight and force of leaning items on unanchored or unbraced shelving may cause the shelving to overturn or collapse.
 11. Shelving (or racks) that are leaning or bending when loaded may indicate a dangerous overload or impending collapse. Loads should be immediately reduced, and the cause for this condition should be corrected, before reloading. Refer to appropriate installation instructions to assure shelving (or racks) are properly assembled, replace any damaged components or parts, and do not exceed recommended maximum loads or engage in any other unsafe use of the shelving (racks).